

acaia

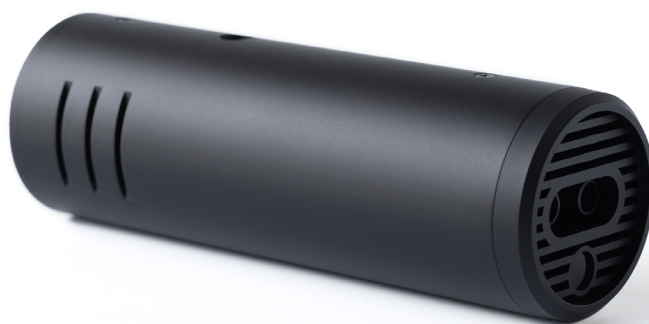

**Acaia Ion Beam
User Manual**

AIM101 / AIM102 / AIM103

Contents

3	Introduction
3	Features
4	In The Box
5	Ion Beam Overview
6	Safety Information
7	Product Care Information
7	Battery Charge
8	Product Cleaning
9	Setting Up the Acaia Ion Beam
9	Using Acaia Ion Beam for the Orbit
10	Using Acaia Ion Beam with a Tripod
11	Operation Instructions
11	Power On / Off
11	Modes
12	Advanced Control with the Orbit App
12	When Connected to the Ion Beam
13	Configuring Ion Beam Settings
14	Appendix
14	Usage
14	Area of Effect
14	Reset to Default
14	Firmware Update
15	Specifications

Introduction

Welcome to your new Acaia Ion Beam.

The Acaia Ion Beam features an industrial-grade ion generator. Designed to address the common issue of static electricity created during the coffee grinding process.

The generator counteracts the positive or negative charges built up during the grinding process. It neutralizes the static electricity that causes coffee grounds to cling together. This reduces the retention of grounds and minimizing flying chaff and clumps.

With the Acaia Ion Beam, you can expect a better coffee grinding experience. Less mess and more consistency.

Features

- Industrial-grade ion generator that generates concentrated, high-density negative or positive ions.
- Works with a range of coffee roasts, from light to dark roasted coffee.
- Automatically begins emitting negative or positive charged ions upon motion detection by the IR sensor, streamlining the coffee grinding process for enhanced efficiency and ease of use.
- Automatically powers off after 120 seconds of use to conserve energy and prevent static electricity accumulation after extended use.
- Portable design to work with different coffee grinders.
- Effectively reduces flying chaffs, clumps and retention for a smoother coffee preparation process.

In The Box

Thank you for choosing one of our products. First, check the package to find the following:



Acaia Ion Beam



L-Shaped Mount

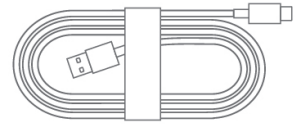

**USB Type-C
Charging Cable**



Spacer x 2



1/4-20x12 Thumb Screw



M3x12 mm Screw



Cleaning Brush

Ion Beam Overview

- Click
- Press and Hold

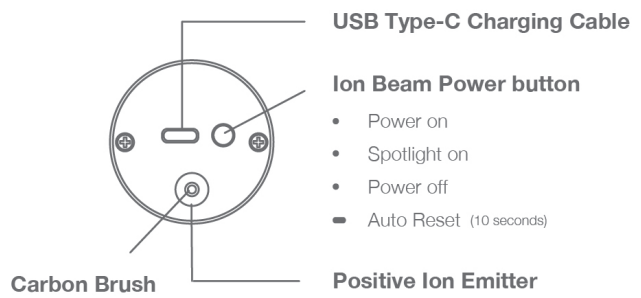
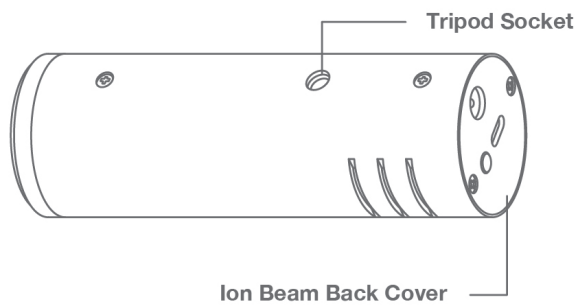
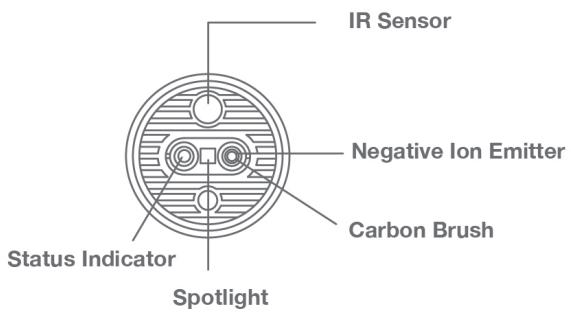
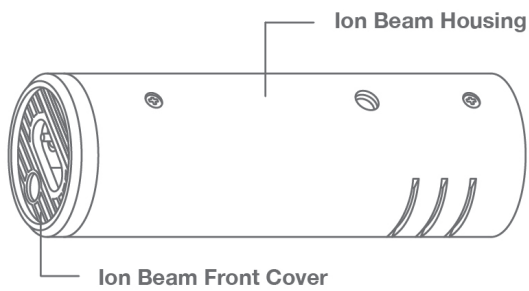

- Ion Beam Power button**
- Power on
 - Spotlight on
 - Power off
 - Auto Reset (10 seconds)

Safety Information

Read the information below carefully before using your Ion Beam. Incorrect handling of this product could result in personal injury or equipment damage. Please keep this manual for future reference.

- ! Do NOT touch the carbon brush in the Ion Beam due to potential high voltage.
- ! Do NOT direct the Ion Beam and its light directly towards human eyes.
- ! Do NOT immerse the Ion Beam in liquids or allow liquids to enter the unit. Use a soft, clean with warm water only to clean the product.
- ! Do NOT allow young children to play with the Ion Beam as it is not a toy.
- ! Do NOT use the Ion Beam if it is not working properly, has been dropped, damaged, or exposed to water.
- ! Never drop or insert objects into any openings.
- ! Do NOT try to disassemble the Ion Beam. Disassembling the unit may cause harm to yourself or damage the equipment, and will void the warranty.
- ! Do NOT operate in areas where aerosol units are being used or where oxygen is being administered.
- ! Do NOT operate the Ion Beam in oxygen-rich environments.
- ! Keep away from gas-powered stoves and ovens, and do not operate the Ion Beam in areas where flammable or combustible units or vapors may be present.
- ! When Ion Beam is turned on, do NOT place it vertically on table for an extended period of time, as static may accumulate on the front or back of the Ion Beam.

Product Care Information

Battery Charge

You can charge the battery by plugging the USB Type-C cable into any of the power supplies listed below:

- A computer
 - A USB wall-charger with an output of 5 volts and 1 amp
 - A USB-C PD charger supporting 5 volts
 - A DC car-charger with an output of 5 volts and 1 amp
-
- When plugging in the Ion Beam for charging, it will automatically turn off. A red charging indicator will be displayed during the charging process. It is possible to use the Ion Beam when it is being charged. Once the Ion Beam is fully charged, the charging indicator will turn off.
 - It takes about 1-2 hours to fully charge the battery when the battery is empty. Try not to let the battery completely run out before charging. Instead, charge the battery as needed.
 - A fully charged battery allows for continuous operation for about 8 hours
 - When the battery level is low, the status light flashes five times as a warning message before turning off.

Product Cleaning

To clean the Ion Beam, follow the steps below:

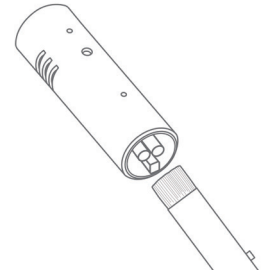
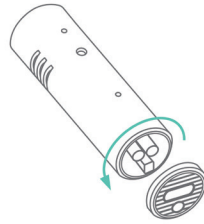

1 Ensure that the Ion Beam is powered off and unplugged to prevent any electrical hazards.

2 Gently turn to remove the front cover of the Ion Beam.

3 Use the provided cleaning brush to gently remove dust or coffee grounds from the sensor.

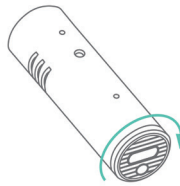
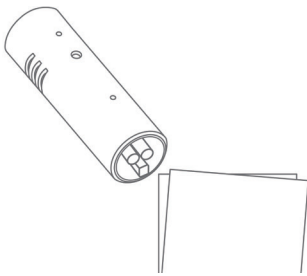

4 After cleaning, examine the sensor for any remaining residue. If necessary, use a soft, lint-free cloth to wipe away the coffee grounds.

5 Reattach the front cover carefully, ensuring it is securely fastened to maintain proper functionality.

6 Once the cover is back in place, power on the Ion Beam and test the IR sensor to confirm that it is functioning correctly.

Note:

- The Acaia Ion Beam is equipped with charging protection to prevent the battery from charging under high temperatures.
- Be cautious not to apply excessive force or use sharp objects during the cleaning process, as this may cause damage to the sensor or its components.
- If you are uncertain about any step or encounter difficulties, please contact our customer support (support@acaia.co) for further assistance.

Setting up the Acaia Ion Beam

Using Acaia Ion Beam with the Orbit

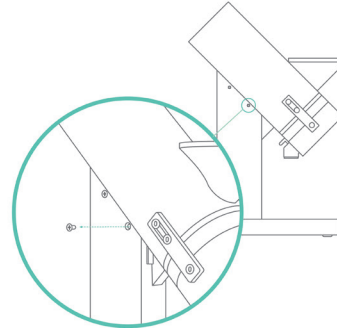

- 1 To install the Ion Beam on the Orbit, you will need: L-Shaped mount x 1, Spacer x 2, 1/4-20x12 Thumb Screw x 1, and M3x12 mm Screw x 1. These are included in the Ion Beam package.

- 2 Remove the M3x8 mm screw on the left side of the motor housing of the Orbit.

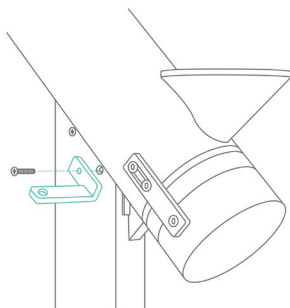

- 3 Align the short side of the L-Shaped mount with the Orbit and secure it in place with an M3x12 mm screw as shown. Ensure the long side of the mount is perpendicular to the Orbit housing.

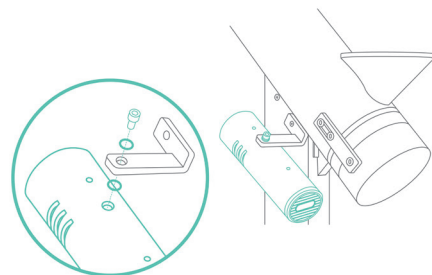

- 4 When installing the Ion Beam, place a spacer on both sides of the screw hole of the L-shaped mount, then secure it with a 1/4-20x12 thumb screw. After installing the Ion Beam, adjust its position to a 45-degree angle toward the chute.

Using Acaia Ion Beam with a Tripod

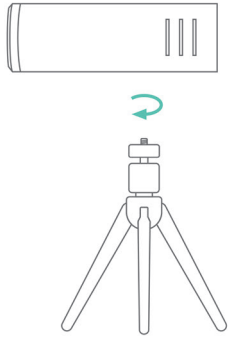

- 1** Insert the tripod screw thread into the designated tripod socket on the Ion Beam. A standard 1/4- inch tripod socket ensures universal compatibility.

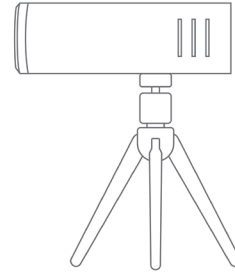

- 2** Rotate the tripod clockwise until it securely attaches to the Ion Beam.

Operation Instructions

Power on / off

1. Click the switch at the bottom of the Ion Beam to power it on. The IR sensor will be activated and the status light will flash twice indicating it's on. During operation, the status light will flash once every 5 seconds.
2. Click again to turn on the spotlight and enter the Continuous Mode.
3. To turn off the Ion Beam, click the switch at the bottom again.

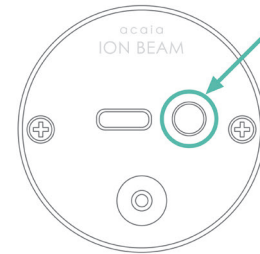

Note: When the Ion Beam's battery is low, the status light will flash for five times as a warning before turning off.

Modes

• IR Mode (Default Setting)

In IR Mode, when an object is placed within 5 cm of the IR sensor, the spotlight turns on and the Ion Beam emits positive and negative ions. If no object is detected, the Ion Beam will enter Sleep Mode after 120 seconds. You can reactivate the Ion Beam by placing an object within range. While in Sleep Mode, the Ion Beam does not emit ions, but the status light will flash every 5 seconds to indicate that the device is in Sleep Mode.

• In Continuous Mode

Both the spotlight and the Ion Beam remain active regardless of object detection by the IR sensor. The Ion Beam automatically powers off after 120 seconds after operation to conserve energy. The Ion Beam's auto-off function prevents excessive static electricity accumulation after extended use.

Note: The settings described above are the default configurations. To adjust the settings, please refer to pages 12 and 13.

Advanced Control with the Orbit App

When Connected to the Ion Beam

A white dot will appear on the Ion Beam icon in the upper left corner.

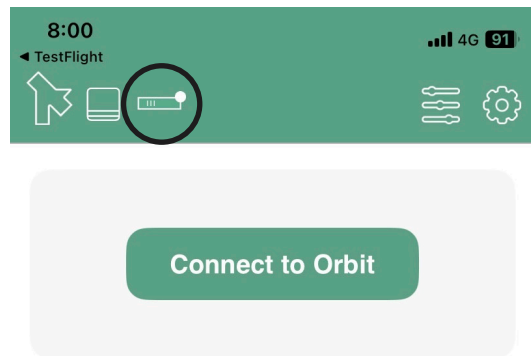

Configuring Ion Beam Settings

To adjust the Ion Beam settings, connect the device to the Acaia Orbit app.

Spotlight

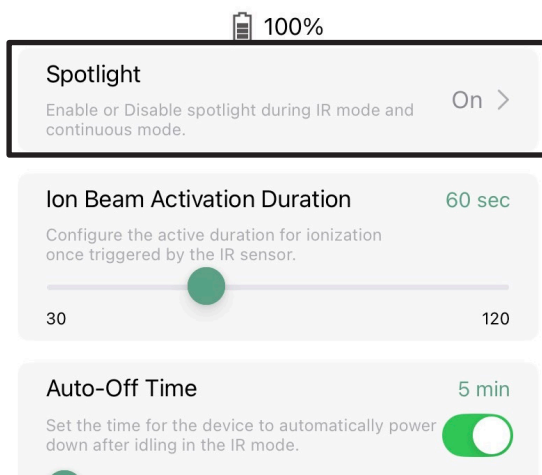

You can enable or disable the spotlight during IR Mode and Continuous Mode.

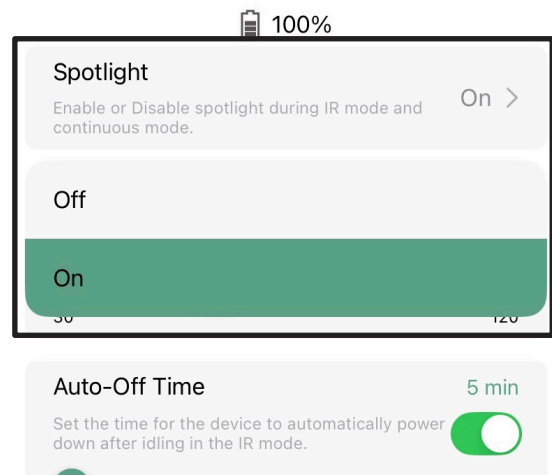

The spotlight can be enabled or disabled in IR Mode and Continuous Mode by selecting On or Off.

Ion Beam Activation Duration (IR Mode Only)

You can set the Ion Beam activation duration between 30 seconds and 120 seconds.

- Continuous Object Detection: The carbon brushes and spotlight will remain active for the set duration (up to 120 seconds) before entering Sleep Mode.
- After an object is detected and then removed, the carbon brushes and spotlight will continue operating until the set time is reached, then enter Sleep Mode.
- If the object is re-detected within the set duration, the timer resets and continues from the new detection time.

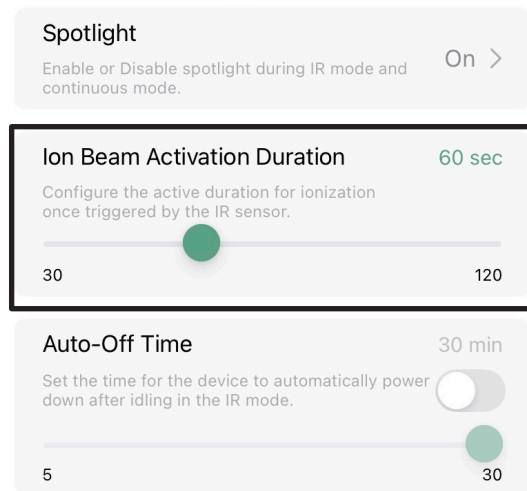

Auto-Off Time (IR Mode Only)

The Auto-Off setting can only be activated and adjusted through the app. Once connected, you can toggle the feature On or Off and set the duration between 5 and 30 minutes.

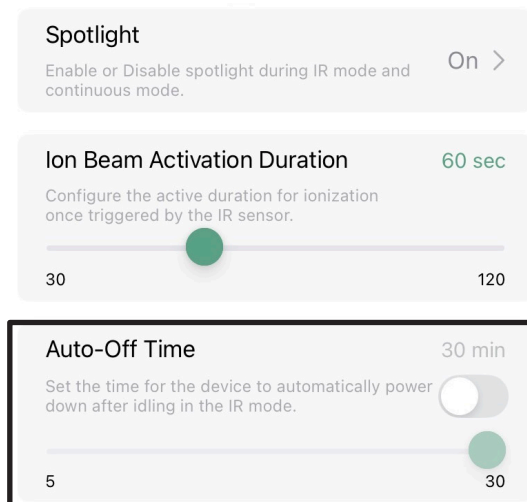

Note: Please make sure that both your Ion Beam and Orbit App are updated to the latest firmware version to access all available features.

Appendix

Usage

Place the Ion Beam as close as possible to your grinder chute and turn on the Ion beam. It works best while shooting the ions from slightly above the exiting path of the grinder. Users may experiment with different angles to find the optimal setup.

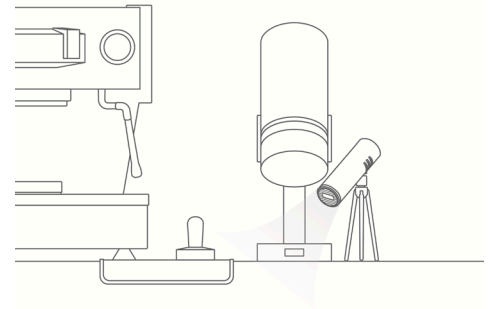

Area of Effect

Depending on the environment, the Ion Beam is most effective when placed as close to the coffee grounds as possible. It usually works within 1 - 5 cm range.

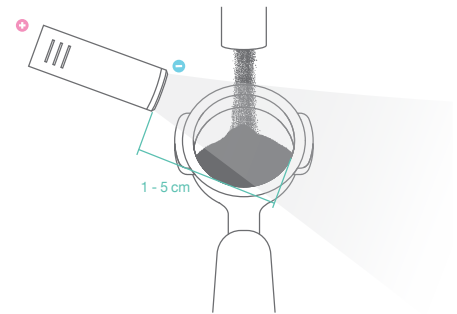

Reset to Default

With the Ion Beam powered off, press and hold the switch for 10 seconds until the indicator flashes, release the switch to reset all settings to default.

Firmware Update

To enter the Update Mode, follow the steps below:

1. Press and the power switch for 10 seconds until the status light displays.
2. Continuing holding the power switch for another 10 seconds; the status light will begin to flash, indicating the Ion Beam is in Update Mode.
3. Once the Ion Beam is connected to the Updater App, the light will stop flashing.
4. Click Update on the Updater App to start the firmware update. The light will flash during the update process.
5. Once the update is completed, the Ion Beam will turn off automatically.

Note: If you wish to exit the Update Mode without updating the firmware, simply leave the Ion Beam untouched. It will automatically power off and exit the Update Mode after 120 seconds of inactivity.

Specifications

Model	AIM101 / AIM102 / AIM103
Product Weight	115 g ± 5 g
Product Dimensions	Ø: 42 mm L: 127 mm
Battery	Lithium-ion rechargeable 3.7 V 780 mAh
Battery Life	8 hours
Material	PC
Connectivity	Bluetooth 5.0
Inside the Package	Acaia Ion Beam x 1 L-Shaped Mount x 1 USB Type-C Cable x 1 Cleaning Brush x 1

Copyright

This user manual is protected by copyright. All rights reserved. No part of this manual may be reproduced, processed, duplicated or published in any form by photocopying, microfilming, reprinting or any other method, in particular electronic means, without the written consent of Acaia.

© Acaia, California, 2025.